

Toyota Truck Camber/Caster Kit Installation Instructions

This kit comes with two steel tubes. You will only use one. Use the bolt with the steel tube for step 4. Use the other bolt for step 7

Installation Instructions:

1. Perform pre-alignment checks in normal manner.
2. Install alignment equipment, record readings and determine amount of camber/caster change needed.
3. Raise front of vehicle by the frame and support in a safe manner.
4. Remove original cam assembly from front position and discard.
5. Inspect new cam bolt kit. Install front washer and steel sleeve on bolt. Washers are stamped with a number, check figure 1 for proper placement. (Note: kit comes with washers already on bolts. Washers need to be removed and assembled per the illustration at right.)
6. Install bolt, second washer and nut. Tighten loosely.
7. Remove OE bolt from rear position and install new bolt.
8. Grease both bolts to reduce possibility of future seizing.
9. Adjust camber/caster to manufacturer's specifications by turning cam until needed adjustment is achieved
10. Tighten nut to manufacturer's specification
11. Proceed with alignment and road test vehicle

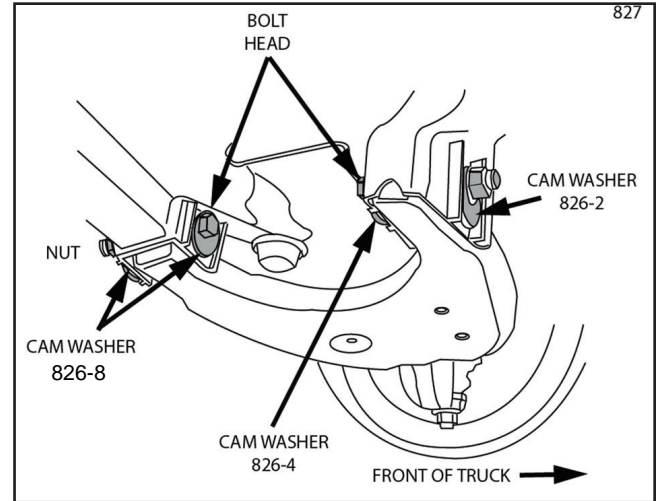

Note: If OE sleeves are seized in bushings, you may need to use an Upper Control Arm Bushing Service Set to help with removal. Otherwise, you may need to replace entire control arm assembly.

95-281-0114

Toyota Truck Camber/Caster Kit Installation Instructions

This kit comes with two steel tubes. You will only use one. Use the bolt with the steel tube for step 4. Use the other bolt for step 7

Installation Instructions:

1. Perform pre-alignment checks in normal manner.
2. Install alignment equipment, record readings and determine amount of camber/caster change needed.
3. Raise front of vehicle by the frame and support in a safe manner.
4. Remove original cam assembly from front position and discard.
5. Inspect new cam bolt kit. Install front washer and steel sleeve on bolt. Washers are stamped with a number, check figure 1 for proper placement. (Note: kit comes with washers already on bolts. Washers need to be removed and assembled per the illustration at right.)
6. Install bolt, second washer and nut. Tighten loosely.
7. Remove OE bolt from rear position and install new bolt.
8. Grease both bolts to reduce possibility of future seizing.
9. Adjust camber/caster to manufacturer's specifications by turning cam until needed adjustment is achieved
10. Tighten nut to manufacturer's specification
11. Proceed with alignment and road test vehicle

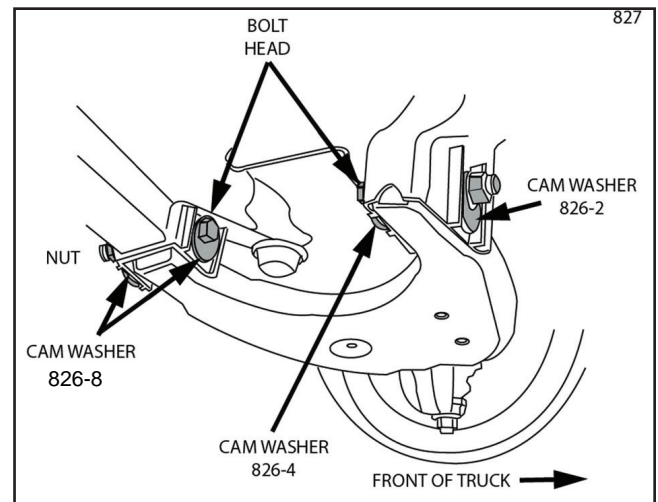

Note: If OE sleeves are seized in bushings, you may need to use an Upper Control Arm Bushing Service Set to help with removal. Otherwise, you may need to replace entire control arm assembly.

95-281-0114